

MODBUS RTU / TCP for maMoS analyser manual v.1.8.2

2020-05

INDEX

INDEX	2
1. Basic connection data	3
1.1. MODBUS RTU.....	3
1.2. MODBUS TCP	3
2. General information about modbus	3
2.1. MODBUS RTU.....	3
2.2. MODBUS TCP	4
3. Modbus connection	5
4. Data type available via modbus:	5
5. MODBUS MAP.....	6
5.1. Coils (1000 code series)	6
5.2. Discrete inputs (2000 code series).....	7
5.3. Holding registers (3000 code series).....	12
5.4. Input registers (4000 code series).....	13
6. Additional tables	20
6.1. Type code table for results presented on analyser's LCD	20
6.2. X,Y, and Z (LSB)	22
6.3. Unit type code table for results presented on analyser's LCD.....	23
6.4. Modbus and Siemens SIMATIC S7-1200 (CPU1211C).....	24
7. Exception codes	24
8. Analogue outputs and relays - terminals	25

1. Basic connection data

1.1. MODBUS RTU

Default address	123
Hardware standard	RS485
Frame format	RTU
Bit rate	9600 bps
Data bits	8
Parity bit type	E
Stop bits	1

1.2. MODBUS TCP

Default TCP port (fixed)	502
--------------------------	-----

2. General information about modbus

Modbus works based on master-slave relation between devices connected in the network, with one master device and all others working as slaves. Master is the only device that can ask questions, while all slaves can only answer. mamos works in slave mode.

2.1. MODBUS RTU

Command in RTU format from master to slave	Answer message in RTU format from slave to master
START BREAK minimum of 3.5 x time for single character transmission	START BREAK minimum of 3.5 × time for single character transmission
ADDRESS of the receiver 1 byte value 0-240	ADDRESS of the slave device 1 byte value 0-240
FUNCTION CODE 1 byte indicates the function code	FUNCTION CODE 1 byte indicates the function code

DATA REGION

n x 1 byte

CRC (checksum)

2 bytes

END BREAK

minimum of 3.5 x time for single character transmission

DATA REGION

n x 1 byte

DATA

n x 1 byte

CRC (checksum)

2 bytes

END BREAK

minimum of 3.5 x time for single character transmission

Maximal length of communicate (with address and CRC) – 256 bytes (**for mamos 128 bytes only**)

Silence longer than 1.5 characters resets the incoming buffer.

2.2. MODBUS TCP

Modbus TCP is a MODBUS RTU message transmitted with a TCP/IP wrapper and sent over a network instead of serial lines.

MODBUS TCP message differs from MODBUS RTU message: it does not have a SlaveID since it uses an IP Address instead; it also does not need CRC, as this is handled by TCP protocol. Detailed description on MODBUS TCP implementation can be found in this manual:

http://www.modbus.org/docs/Modbus_Messaging_Implementation_Guide_V1_0b.pdf

Example of Modbus RTU request for the content of analogue output holding registers # 40108 to 40110 from the slave device with address 17:

11 03 006B 0003 7687

11: The SlaveID Address (17 = 11 hex)

03: The Function Code (read Analog Output Holding Registers)

006B: The Data Address of the first register requested. (40108-40001 = 107 =6B hex)

0003: The total number of registers requested. (read 3 registers 40108 to 40110)

7687: The CRC (cyclic redundancy check) for error checking.

In Modbus TCP, neither SlaveID nor CRC are necessary, therefore the same request, but in MODBUS TCP (before TCP encapsulation), is **03 006B 0003**

3. Modbus connection

Modbus RTU, TCP terminal is positioned at the bottom part of mamos:

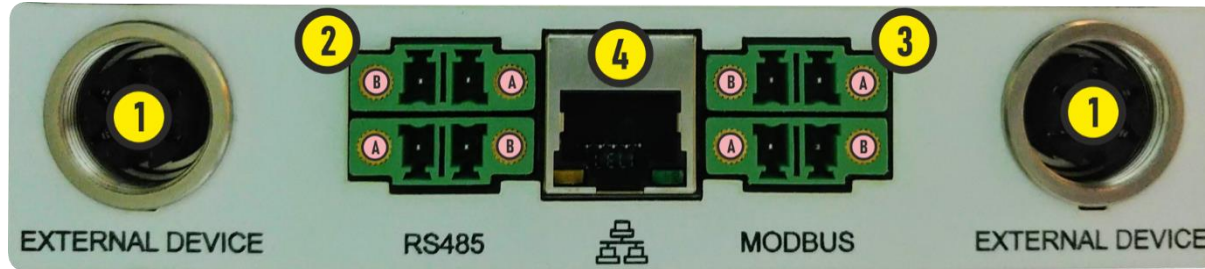

1. Connectors for external devices, like MD3 gas dryer
2. RS485 communication using madur communication interface
PLUG type: MC 1,5/2-ST1F-5.08
3. MODBUS RTU connector
PLUG type: MC 1,5/2-ST1F-5.08
4. RJ-45 Ethernet connector – allows for simultaneous MODBUS TCP and madur interface connections

4. Data type available via modbus:

Coils (single bit)

read/write

command code: 1 (read coil status)/5 (force single coil)

addresses: 1001-1003

Discrete Input (single bit)

read only

command code 2 (read input status)

addresses: 2001-2039

2040 (introduced in LCD driver ver. 1.7)

Holding registers (16-bit word)

read/write

command code: 3 (read holding register)/6 (pre-set single register)

addresses: 3001-3015

Input registers (16-bit word)

read only

command code: 4 (read input register)

Addresses: 4001-4040

4041-4052 (introduced in LCD driver ver. 1.7)

Maximal length of a message for MODBUS RTU (with address and CRC) for mamos analyser is **128 bytes**.

5. MODBUS MAP

5.1. Coils (1000 code series)

This read/write one bit data is available via modbus under these codes:

READ COILS **Command: 1**

WRITE SINGLE COIL **Command: 5**

Address	Name	Alt Name		Description
1001	COIL1	Relay4	Open drain output	User programmable switch, available on outputs socket board See page 25, for details Max 30VDC, 1A
1002	COIL2	Vacat2	Open drain output Vacat 2	When switched on/off connects/disconnects from ground (GND) Allows for relays connection See page 25 for details Max 30VDC, 1A
1003	COIL3	Vacat3	Open drain output Vacat 3	When switched on/off connects/disconnects from ground (GND) Allows for relays connection See page 25 for details Max 30VDC, 1A
1004	COIL4	MasterOnBus	0/1 = slave/master	1=master 0=slave
1005	COIL5	Checking1	Checking1 mode request	Checking1 mode request
1006	COIL6	Checking1	Checking2 mode request	Checking2 mode request
1007	COIL7	StartCycle	Starts measurement cycle from Zeroing phase	Starts measurement cycle from Zeroing phase
1008	COIL8	TerminateCycle	Terminates measurement cycle and goes to BeforeStandby phase	Terminates measurement cycle and goes to BeforeStandby phase

5.2. Discrete inputs (2000 code series)

This read only one bit data is available via modbus under these codes:

READ DISCRETE INPUT

Command: 2

Address prefix for PLC	Name	Alt Name	Description
2001 12001*	DI1	Relay1	Relay1 control; Hi=ON
			Relays are mamos optional equipment (not present in every device) Relay is controlled and switched by mamos Connection with +12 DC power Open drain type For details see photo on page 25, When OFF: pins 2 and 3 are connected When ON: pins 1 and 2 are connected
2002 12002*	DI2	Relay2	Relay2 control; Hi=ON
			Relays are mamos optional equipment (not present in every device) Relay is controlled and switched by mamos Connection with +12 DC power Open drain type For details see photo on page 25, When OFF: pins 2 and 3 are connected When ON: pins 1 and 2 are connected
2003 12003*	DI3	Relay3	Relay3 control; Hi=ON
			Open drain switch For details see photo on page 25,
2004 12004*	DI4	Relay4	Open drain output switch; Hi=ON
			User programmable switch, available on outputs socket board Check page 25, for details Max 30VDC, 1A
2005 12005*	DI5	Relay5	
2006 12006*	DI6	Relay6	
2007 12007*	DI7	Relay7	
2008 12008*	DI8	Relay8	
			For future use, always 0
			For internal use only No connections provided

Address prefix for PLC	Name	Alt Name	Description	
2009 12009*	DI9	In1	Digital input1	Digital input (located on analogue I/O board), allows to restart/ terminate mamos measurement cycle TTL levels (in relation to mamos GND), Schmitt trigger, accepts up to 24 VDC Floating = high level Connection: pin 5 in TOP ROW, REAR
2010 12010*	DI10	In2	Digital input2	Digital input (located on analogue I/O board), allows to restart/ terminate mamos measurement cycle TTL levels (in relation to mamos GND), Schmitt trigger accepts up to 24 VDC Floating = high level = 0 Connection: pin 5 in TOP ROW, FRONT and any of GND pins
2011 12011*	DI11	In3	Digital input3	For internal use only No connections provided
2012 12012*	DI12	In4	Digital input4	
2013 12013*	DI13	In5	Digital input5 dip switch status	
2014 12014*	DI14	In6	Digital input6 dip switch status	
2015 12015*	DI15	In7	for future use, always 0	
2016 12016*	DI16	In8	for future use, always 0	
2017 12017*	DI17	Valvell	auxiliary channel valve, status 1=ON	Valve in optional AUX gas channel (provided for fragile gas sensors like H ₂ S or CO) Modes: ventilation/measurement 0=measurement
2018 12018*	DI18	PumpII	auxiliary channel pump, status 1=ON	Pump for ventilation of AUX channel 0=OFF (0 = measurement in progress, ventilation pump for AUX channel not working)
2019 12019*	DI19	Fan1	Main fan for mamos case, status 1=ON	Main ventilating fan for mamos case 0=OFF Positioned inside the mamos case, bottom left corner. Settings for fan available in Settings--> Stabilisation of internal temperature

Address prefix for PLC	Name	Alt Name	Description
2020 12020*	DI20	PeltierIn	peltier element in mamos gas dryer; status 0=ON Cooling element for mamos MD2 gas dryer, available for compact mamos with MD2 gas dryer only. FYI, MD3 gas dryer controls peltier elements at own discretion. 0=OFF
2021 12021*	DI21	Vacat2	open drain output Vacat 2 – real value When switched on connects to ground (GND) Allows for relays connection See page 25 for details
2022 12022*	DI22	Vacat3	open drain output Vacat 3 – real value When switched on connects to ground (GND) Allows for relays connection See page 25 for details
2023 12023*	DI23	Valve4PdifZeroing	Zeroing valve for differential pressure sensor Two valves coupled together for differential pressure sensor, switch between work mode (0) and calibration mode (1) 0=OFF (work mode)
2024 12024*	DI24	BlowBackValve	Status of probe's valve for auto ventilation purpose; status 1=ON Blowback valve is an optional equipment for mamos (for stationary gas probe with automatic cleaning option), allows automatic cleaning of filter with compressed air. Filter's cleaning is performed during ventilation of mamos gas sensors 0=OFF
2025 12025*	DI25	PdifZeroing	Status of valve for calibration of differential pressure sensor 2 coupled valves for calibration of differential pressure sensor. 0=calibration off (differential pressure sensor is measuring)
2026 12026*	DI26	EvenCycle	Information about current source of gas sample (for mamos twin-split configuration) Mamos can work in compact, split and twin-split configurations. In twin-split configuration two gas sources can be measured (in turns). This discrete input informs from which source mamos is collecting sample. 1= EVEN, 0=ODD
2027 12027*	DI27	EvenCycleNext	Information about next source of gas sample (for mamos twin-split configuration) Information about the source of the next measurement cycle. 1=EVEN, 0=ODD
2028 12028*	DI28	MeasureMplusA	AUX channel measurement status (M+A) AUX channel is introduced to mamos in order to protect sensitive sensors or to prolong their lifetime (e.g. CO, H ₂ S) 0=OFF (1=WORK) (0 means AUX channel is in ventilation or standby mode = sensors in AUX channel are not measuring)

Address prefix for PLC	Name	Alt Name		Description
2029 12029*	DI29	OverDraft	Overdraft status for latched values on analogue	Values on analogue outputs are latched (on the last correct value) for the time of sensor's ventilation. Overdraft is additional time (beyond ventilation) when values are still being latched (in order to gas reach sensors after ventilation). See more information about Overdraft (Infusion) time in the user manual. 0=OFF
2030 12030*	DI30	IsMMCSlot	Datalogger status	Information if the mamos is equipped with optional data-logger 0=NOT PRESENT
2031 12031*	DI31	IsMMCCard	Memory card status	Status of SD card presence in mamos data-logger 0=NOT PRESENT
2032 12032*	DI32	IsAD7705	Differential pressure sensor	AD7705 is A/D converter for differential pressure sensor. It is present when differential pressure sensor is present. 0=NO PRESSURE SENSOR PRESENT
2033 12033*	DI33	IsSwitch	Mode switch status 0=not present, 1=present	Status for mamos mode switch presence 0=NO WORK MODE SWITCH PRESENT
2034 12034*	DI34	Standby	Status for Forced standby mode (in long-term working modes)	Mamos can work in long-term modes (1÷30 days). This discrete input informs if mamos is in stand-by mode 0=OFF
2035 12035*	DI35	OverPressure	Pressure exceed error (for mamos pressurised version only)	Optional, pressurised version of mamos analyser can work up to 1,8bar. This output informs when pressure limit is exceeded. 0=NO OVERPRESSURE ALARM
2036 12036*	DI36	AuxOverranged	Result that triggers AUX channels was exceeded	AUX-iliary channel in mamos can be triggered with time or with the threshold result from other sensor. AUX channel can be set in mamos program: Setting available in Settings→ Auxiliary channel 0=NO OVERRANGE ALARM (AUX channel is enabled)
2037 12037*	DI37	DryerError	Dryer Error	Discrete input meaningful only for mamos with MD2 gas dryer (compact configuration) Alarm triggered if Peltier cooling element does not switch ON/OFF for time longer that 60 seconds 0=NO DRYER ERROR ALARM

Address prefix for PLC	Name	Alt Name		Description
2038 12038*	DI38	FlowTooLow	Flow too low	Mamos is equipped with sensor that controls flow measurement through device. If flow drops below specified value an error is reported. Flow control threshold value can be set in mamos program: Settings-->Gas pump 0=NO FLOW TOO LOW ALARM
2039 12039*	DI39	NoActivePoints	Error control for work modes: Measurements triggered by a digital input Measurements according to scheduler	One of the work modes (listed on the left) was selected, but none triggering points are selected (mamos will not start measurements at any time) 0=NO ALARM
2040 12040*	DI40	Valve1	Ventilation valve status	Informs about status of main valve for ventilation purposes 1=ON (mamos is ventilating)
2041-2100 12041-12100*	DI41-DI100	---	for future use, always 0	For internal use only No connections provided

* address with prefix for programmable logic controller (tested with Siemens S7 controller) enabling the controller to recognise data type:

Coils – no prefix needed

Discrete inputs – 1

Holding registers – 4

Input registers – 3

5.3. Holding registers (3000 code series)

This read/write two byte data is available via modbus under these codes:

READ HOLDING REGISTER **Command: 3**

WRITE SINGLE REGISTER **Command: 6**

Address prefix for PLC	Name	Alt Name	Description
3001 43001*	HR1	MBOwnAddress	Address (MSB) and Anti-address (LSB) in modbus communication 123 by default 2 bytes: MSB – (more significant byte) – device address in binary code LSB – anti-address of the device: To change the address of the analyser both Address and Anti-address must be changed, only then the analyser will accept the new address (see the below picture)
3002 43002*	HR2	ModbusPWM	PWM setting 0..65535 5V Connection in mamos: 1 in TOP ROW (REAR) – for 5V
3003 43003*	HR3	MBModeChange	Work mode change 055H – Scheduler 05AH – Digital inputs 0A5H – Cyclic 0A6H – FlipFlop Other – no effect
3004 43004*	HR4	MBPhaseChange	Work phase change 1 – Zeroing 2 – Measurements 3 – Standby Other – no effect
3005 43005*	HR5	MBChannelChange	Measurement channel change: 0 – channel A 1 – channel B 2 – channel C ... 7 – channel H
3006 – 3013 43006-43013*	HR4-HR13	---	for future use Internal use only No connections provided

3014 43014*	HR14	DeviceLEDMask	LED and buzzer ON/OFF	Enable (1) or disable (0) LED and buzzer
3015 43015*	HR15	Device4Display	Brand	Device brand on LCD
3016 43016*	HR16	ModbusCoils	Reserved!	Reserved!

Address and anti-address coding in binary system.

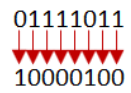
123 address in decimal system
 01111011 address in binary system

 10000100 anti-address in binary system

5.4. Input registers (4000 code series)

This read only two byte data is available via modbus under these codes:

READ INPUT REGISTERS **Command: 4**

Address prefix for PLC	Name	Alt Name	Description
4001 34001*	IR1	MBResult0	#1LCD measurement result, 2 bytes, Integer U2 2 bytes Setting available in Settings-->Displays
4002 34002*	IR2	MBResult1	#2LCD measurement result, 2 bytes, Integer U2 2 bytes Setting available in Settings-->Displays
4003 34003*	IR3	MBResult2	#3LCD measurement result, 2 bytes, Integer U2 2 bytes Setting available in Settings-->Displays
4004 34004*	IR4	MBResult3	#4LCD measurement result, 2 bytes, Integer U2 2 bytes Setting available in Settings-->Displays

Address prefix for PLC	Name	Alt Name		Description
4005 34005*	IR5	MBResult4	#5LCD measurement result, 2 bytes, Integer U2	Result from measurement assigned to #5LCD 2 bytes Setting available in Settings-->Displays
4006 34006*	IR6	MBResult5	#6LCD measurement result, 2 bytes, Integer U2	Result from measurement assigned to #6LCD 2 bytes Setting available in Settings-->Displays
4007 34007*	IR7	MBResult6	#7LCD measurement result, 2 bytes, Integer U2	Result from measurement assigned to #7LCD 2 bytes Setting available in Settings-->Displays
4008 34008*	IR8	MBResult7	#8LCD measurement result, 2 bytes, Integer U2	Result from measurement assigned to #8LCD 2 bytes Setting available in Settings-->Displays
4009 34009*	IR9	MBResultCode0	#1 LCD result code type	Code for result type of measurement in #1LCD (type code description in a table below)
4010 34010*	IR10	MBResultCode1	#2 LCD result code type	Code for result type of measurement in #2LCD (type code description in a table below)
4011 34011*	IR11	MBResultCode2	#3 LCD result code type	Code for result type of measurement in #3LCD (type code description in a table below)
4012 34012*	IR12	MBResultCode3	#4 LCD result code type	Code for result type of measurement in #4LCD (type code description in a table below)
4013 34013*	IR13	MBResultCode4	#5 LCD result code type	Code for result type of measurement in #5LCD (type code description in a table below)
4014 34014*	IR14	MBResultCode5	#6 LCD result code type	Code for result type of measurement in #6LCD (type code description in a table below)
4015 34015*	IR15	MBResultCode6	#7 LCD result code type	Code for result type of measurement in #7LCD (type code description in a table below)
4016 34016*	IR16	MBResultCode7	#8 LCD result code type	Code for result type of measurement in #8LCD (type code description in a table below)
4017 34017*	IR17	MBUnitDP0	Unit code (MS byte) and precision point (LS byte) for result in #1 LCD	Unit code (MS byte) and precision point (LS byte) for result in #1 LCD (unit type code description in tables below)

Address prefix for PLC	Name	Alt Name		Description
4018 34018*	IR18	MBUnitDP1	Unit code (MS byte) and precision point (LS byte) for result in #2 LCD	Unit code (MS byte) and precision point (LS byte) for result in #2 LCD (unit type code description in tables below)
4019 34019*	IR19	MBUnitDP2	Unit code (MS byte) and precision point (LS byte) for result in #3 LCD	Unit code (MS byte) and precision point (LS byte) for result in #3 LCD (unit type code description in tables below)
4020 34020*	IR20	MBUnitDP3	Unit code (MS byte) and precision point (LS byte) for result in #4 LCD	Unit code (MS byte) and precision point (LS byte) for result in #4 LCD (unit type code description in tables below)
4021 34021*	IR21	MBUnitDP4	Unit code (MS byte) and precision point (LS byte) for result in #5 LCD	Unit code (MS byte) and precision point (LS byte) for result in #5 LCD (unit type code description in tables below)
4022 34022*	IR22	MBUnitDP5	Unit code (MS byte) and precision point (LS byte) for result in #6 LCD	Unit code (MS byte) and precision point (LS byte) for result in #6 LCD (unit type code description in tables below)
4023 34023*	IR23	MBUnitDP6	Unit code (MS byte) and precision point (LS byte) for result in #7 LCD	Unit code (MS byte) and precision point (LS byte) for result in #7 LCD (unit type code description in tables below)
4024 34024*	IR24	MBUnitDP7	Unit code (MS byte) and precision point (LS byte) for result in #8 LCD	Unit code (MS byte) and precision point (LS byte) for result in #8 LCD (unit type code description in tables below)
4025 34025*	IR25	MBAnaoutU1	Voltage value forced in analogue output U1, 2 bytes UINT in mV	Voltage value forced in analogue output U1 2 bytes UINT in mV
4026 34026*	IR26	MBAnaoutU2	Voltage value forced in analogue output U2, 2 bytes UINT in mV	Voltage value forced in analogue output U2 2 bytes UINT in mV
4027 34027*	IR27	MBAnaoutU3	Voltage value forced in analogue output U3, 2 bytes UINT in mV	Voltage value forced in analogue output U3 2 bytes UINT in mV
4028 34028*	IR28	MBAnaoutU4	Voltage value forced in analogue output U4, 2 bytes UINT in mV	Voltage value forced in analogue output U4 2 bytes UINT in mV
4029 34029*	IR29	MBAnaoutI1	Current value forced in analogue output I1, 2 bytes UINT in μ A	Current value forced in analogue output I1 2 bytes UINT in μ A
4030 34030*	IR30	MBAnaoutI2	Current value forced in analogue output I2, 2 bytes UINT in μ A	Current value forced in analogue output I2 2 bytes UINT in μ A
4031 34031*	IR31	MBAnaoutI3	Current value forced in analogue output I3, 2 bytes UINT in μ A	Current value forced in analogue output I3 2 bytes UINT in μ A

Address prefix for PLC	Name	Alt Name		Description
4032 34032*	IR32	MBAnaoutI4	Current value forced in analogue output I4, 2 bytes UINT in μ A	Current value forced in analogue output I4 2 bytes UINT in μ A
4033 34033*	IR33	MBAnaOutCodeU1	Code for result type in analogue output U1	Code for result type of measurement in analogue output U1 (type code description in a table below)
4034 34034*	IR34	MBAnaOutCodeU2	Code for result type in analogue output U2	Code for result type of measurement in analogue output U2
4035 34035*	IR35	MBAnaOutCodeU3	Code for result type in analogue output U3	Code for result type of measurement in analogue output U3
4036 34036*	IR36	MBAnaOutCodeU4	Code for result type in analogue output U4	Code for result type of measurement in analogue output U4
4037 34037*	IR37	MBAnaOutCodeI1	Code for result type in analogue output I1	Code for result type of measurement in analogue output I1
4038 34038*	IR38	MBAnaOutCodeI2	Code for result type in analogue output I2	Code for result type of measurement in analogue output I2
4039 34039*	IR39	MBAnaOutCodeI3	Code for result type in analogue output I3	Code for result type of measurement in analogue output I3
4040 34040*	IR40	MBAnaOutCodeI4	Code for result type in analogue output I4	Code for result type of measurement in analogue output I4
4041 34041*	IR41	MamosMode	Information about selected work mode	000H – manual (mode triggered with work knob) 055H – according to scheduler 05AH – Triggered by digital inputs 0A5H – Cyclic work mode 0B0H – Monthly-cyclic mode 0B1H – Monthly-cyclic mode with adjustable length (1-30 days)

Address prefix for PLC	Name	Alt Name		Description																		
4042 34042*	IR42	MamosStatus	Information about current phase of mamos work	0 – Warming 1 – Zeroing 2 – Measuring 3 – Initial phase of standby (purging of gas path) 4 – Standby 5 – Display test 6 – Display identification 7 – The first zeroing (after warming) 8 – Initial phase of measurements (infusion of gas)																		
4043 34043*	IR43	SDStatus	Status concerning SD card and data-logging	0 – no card present 1 – card present, storage OFF 2 – card present, storage ON 3 – card present, finishing data-logging 4 – card present, data-logging withhold 5 – card present, initialisation 6 – card present, error occurred 7 – formatting of SD card																		
4044 34044*	IR44	SwitchPosition	Determines the position of work knob	<table border="0"> <tr> <td>Compact configuration</td> <td>Twin split configuration</td> </tr> <tr> <td>0 – Auto</td> <td>0 – Auto</td> </tr> <tr> <td>1 – Measurements</td> <td>1 – Measurements A</td> </tr> <tr> <td>2 – Zeroing</td> <td>2 – Zeroing</td> </tr> <tr> <td>3 – Standby</td> <td>3 – Standby</td> </tr> <tr> <td>4 – Service</td> <td>4 – Service</td> </tr> <tr> <td>6 – Measurements A+AUX</td> <td>5 – Measurements B</td> </tr> <tr> <td></td> <td>6 – Measurements A+AUX</td> </tr> <tr> <td></td> <td>7 – Measurements B+AUX</td> </tr> </table>	Compact configuration	Twin split configuration	0 – Auto	0 – Auto	1 – Measurements	1 – Measurements A	2 – Zeroing	2 – Zeroing	3 – Standby	3 – Standby	4 – Service	4 – Service	6 – Measurements A+AUX	5 – Measurements B		6 – Measurements A+AUX		7 – Measurements B+AUX
Compact configuration	Twin split configuration																					
0 – Auto	0 – Auto																					
1 – Measurements	1 – Measurements A																					
2 – Zeroing	2 – Zeroing																					
3 – Standby	3 – Standby																					
4 – Service	4 – Service																					
6 – Measurements A+AUX	5 – Measurements B																					
	6 – Measurements A+AUX																					
	7 – Measurements B+AUX																					
4045 34045*	IR45	Hour		Hour BCD 00hh																		
4046 34046*	IR46	MinSec	Date and time in mamos	Minute and second BCD mmss																		
4047 34047*	IR47	Year		Year BCD YYYY																		

Address prefix for PLC	Name	Alt Name		Description
4048 34048*	IR48	MonthDay		Month and day BCD MMDD
4049 34049*	IR49	NextZeroHour		Hour BCD 00hh
4050 34050*	IR50	NextZeroMinSec	Date and time of the next zeroing	Minute and second BCD mmss
4051 34051*	IR51	NextZeroYear		Year BCD YYYY
4052 34052*	IR52	NextZeroMonthDay		Month and day BCD MMDD
4053 34053*	IR53	MBGasChannel	connected gas channel	Currently connected gas channel
4054 34054*	IR54	MBGasChannels	number of installed gas channels	Number of installed gas channels
4055÷4060 34055-34060*	IR55÷IR60		for future use	Internal use only No connections provided
4061 34061*	IR61	MBResult8	#9LCD measurement result, 2 bytes, Integer U2	Result from measurement assigned to #9LCD 2 bytes Setting available in Settings-->Displays
4062 34062*	IR62	MBResult9	#10LCD measurement result, 2 bytes, Integer U2	Result from measurement assigned to #10LCD 2 bytes Setting available in Settings-->Displays
4063 34063*	IR63	MBResult10	#11LCD measurement result, 2 bytes, Integer U2	Result from measurement assigned to #11LCD 2 bytes Setting available in Settings-->Displays
4064 34064*	IR64	MBResult11	#12LCD measurement result, 2 bytes, Integer U2	Result from measurement assigned to #12LCD 2 bytes Setting available in Settings-->Displays
4065 34065*	IR65	MBResult12	#13LCD measurement result, 2 bytes, Integer U2	Result from measurement assigned to #13LCD 2 bytes Setting available in Settings-->Displays

Address prefix for PLC	Name	Alt Name		Description
4066 34066*	IR66	MBResult13	#14LCD measurement result, 2 bytes, Integer U2	Result from measurement assigned to #14LCD 2 bytes Setting available in Settings-->Displays
4067 34067*	IR67	MBResult14	#15LCD measurement result, 2 bytes, Integer U2	Result from measurement assigned to #15LCD 2 bytes Setting available in Settings-->Displays
4068 34068*	IR68	MBResult15	#16LCD measurement result, 2 bytes, Integer U2	Result from measurement assigned to #16LCD 2 bytes Setting available in Settings-->Displays
4069 34069*	IR69	MBResultCode8	#9 LCD result code type	Code for result type of measurement in #9LCD (type code description in a table below)
4070 34070*	IR70	MBResultCode9	#10 LCD result code type	Code for result type of measurement in #10LCD (type code description in a table below)
4071 34071*	IR71	MBResultCode10	#11 LCD result code type	Code for result type of measurement in #11LCD (type code description in a table below)
4072 34072*	IR72	MBResultCode11	#12 LCD result code type	Code for result type of measurement in #12LCD (type code description in a table below)
4073 34073*	IR73	MBResultCode12	#13 LCD result code type	Code for result type of measurement in #13LCD (type code description in a table below)
4074 34074*	IR74	MBResultCode13	#14 LCD result code type	Code for result type of measurement in #14LCD (type code description in a table below)
4075 34075*	IR75	MBResultCode14	#15 LCD result code type	Code for result type of measurement in #15LCD (type code description in a table below)
4076 34076*	IR76	MBResultCode15	#16 LCD result code type	Code for result type of measurement in #16LCD (type code description in a table below)
4077 34077*	IR77	MBUnitDP8	Unit code (MS byte) and precision point (LS byte) for result in #9 LCD	Unit code (MS byte) and precision point (LS byte) for result in #9 LCD (unit type code description in tables below)
4078 34078*	IR78	MBUnitDP9	Unit code (MS byte) and precision point (LS byte) for result in #10 LCD	Unit code (MS byte) and precision point (LS byte) for result in #10 LCD (unit type code description in tables below)

Address prefix for PLC	Name	Alt Name		Description
4079 34079*	IR79	MUnitDP10	Unit code (MS byte) and precision point (LS byte) for result in #11 LCD	Unit code (MS byte) and precision point (LS byte) for result in #11 LCD (unit type code description in tables below)
4080 34080*	IR80	MUnitDP11	Unit code (MS byte) and precision point (LS byte) for result in #12 LCD	Unit code (MS byte) and precision point (LS byte) for result in #12 LCD (unit type code description in tables below)
4081 34081*	IR81	MUnitDP12	Unit code (MS byte) and precision point (LS byte) for result in #13 LCD	Unit code (MS byte) and precision point (LS byte) for result in #13 LCD (unit type code description in tables below)
4082 34082*	IR82	MUnitDP13	Unit code (MS byte) and precision point (LS byte) for result in #14 LCD	Unit code (MS byte) and precision point (LS byte) for result in #14 LCD (unit type code description in tables below)
4083 34083*	IR83	MUnitDP14	Unit code (MS byte) and precision point (LS byte) for result in #15 LCD	Unit code (MS byte) and precision point (LS byte) for result in #15 LCD (unit type code description in tables below)
4084 34084*	IR84	MUnitDP15	Unit code (MS byte) and precision point (LS byte) for result in #16 LCD	Unit code (MS byte) and precision point (LS byte) for result in #16 LCD (unit type code description in tables below)
4085-4100 34085-34100*	IR85-IR100		For future use, always 0	Internal use only No connections provided

* address with prefix for programmable logic controller (tested with Siemens S7 controller) enabling the controller to recognise data type:

Coils – no prefix needed

Discrete inputs – 1

Holding registers – 4

Input registers – 3

6. Additional tables

6.1. Type code table for results presented on analyser's LCD

0 O ₂	10 Y (see table below)	20 PT500 T4	30 NO ₂ mg	40 UI1	50 BL_Null results from SPI that are not recognised	60 Zrel
1 CO ₂	11 Z (see table below)	21 SL	31 NO _x mg	41 UI2	51 CH ₄ rel	61 not used
2 CH ₄	12 not used	22 Internal temperature	32 SO ₂ mg	42 UI3	52 CO rel	62 not used

3 CO	13 not used	23 Eta	33 H ₂ S mg	43 UI4	53 NO rel	63 Medium pressure - pressure of tested gas
4 NO	14 Pump flow	24 Lam	34 X mg	44 UI5	54 NO ₂ rel	
5 NO ₂	15 Ambient Pressure	25 Flow	35 Y mg	45 UI6	55 NO _x rel	
6 NO _x	16 Differential Pressure	26 Relative Humidity	36 Z mg	46 UI7	56 SO ₂ rel	
7 SO ₂	17 Ambient temperature	27 CH ₄ mg	37 not used	47 not used	57 H ₂ S rel	
8 H ₂ S	18 Gas temperature	28 CO mg	38 not used	48 not used	58 X rel	
9 X (see table below)	19 K type T3	29 NO mg	39 UI0	49 not used	59 Y rel	

6.2. X,Y, and Z (LSB)

Value (dec)	Sensor type
14	H2
15	NH3
16	Cl2
17	HCl
32	N2O
34	CHF3
43	VOC
44	H2 (TCD)
52	He (TCD)
58	C4H8 (VOC)

6.3. Unit type code table for results presented on analyser's LCD

Value	Name	Unit
0	UnitPPM	ppm
1	UnitPROCENT	%
2	UnitDEGC	°C
3	UnitDEGF	°F
4	UnitMGM3	mg/m ³
5	UnitGGJ	g/GJ
6	UnitHPA	hPa
7	UnitPA	Pa
8	UnitMMH2O	mmH ₂ O
9	UnitINH2O	inH ₂ O
10	UnitMS	m/s
11	UnitmV	mV
12	UnitV	V
13	UnitmA	mA
14	UnitA	A
15	UnitNONE	–
16	UnitGM3	g/m ³
17	UnitLPH	l/h
18	UnitUnknown	Unknown unit

6.4. Modbus and Siemens SIMATIC S7-1200 (CPU1211C)

maMos analyser was tested with Siemens controller and so, some documents are available for download from our website.

7. Exception codes

Following a request, there are 4 possible outcomes from the slave:

- The request is successfully processed by the slave and a valid response is sent.
- The request is not received by the slave therefore no response is sent.
- The request is received by the slave with a parity, CRC or LRC error.
The slave ignores the request and sends no response.
- The request is received without an error, but cannot be processed by the slave for another reason. The slave replies with an exception response.

In a normal response, the slave echoes the function code. The first sign of an exception response is that the function code is shown in the echo with its highest bit set. All function codes have 0 for their most significant bit. Therefore, setting this bit to 1 is the signal that the slave cannot process the request.

maMos supports these exception codes:

02 – Illegal data access

The data address received in the query is not an allowable address for the slave. More specifically, the combination of reference number and transfer length is invalid. For a controller with 100 registers, a request with offset 96 and length 4 would succeed, a request with offset 96 and length 5 will generate exception 02

03 – Illegal data value

A value contained in the query data field is not an allowable value for the slave. This indicates a fault in the structure of remainder of a complex request, such as that the implied length is incorrect. It specifically does NOT mean that a data item submitted for storage in a register has a value outside the expectation of the application program, since the MODBUS protocol is unaware of the significance of any particular value of any particular register.

8. Analogue outputs and relays - terminals

1. Analogue outputs - top row (rear)

- 1.1. PWM
- 1.2. RELAY 3 – Open-drain output
- 1.3. RELAY 4 – Open-drain output
- 1.4. +12V
- 1.5. Digital Input #1
- 1.6. U1 (voltage output #1)
- 1.7. U2 (voltage output #2)
- 1.8. U3 (voltage output #3)
- 1.9. U4 (voltage output #4)
- 1.10. GND

2. Analogue outputs - bottom row (front)

- 2.1. GND
- 2.2. GND
- 2.3. GND
- 2.4. VCC (+5VDC)
- 2.5. Digital Input #2
- 2.6. I1 (current output #1)
- 2.7. I2 (current output #2)
- 2.8. I3 (current output #3)
- 2.9. I4 (current output #4)
- 2.10. GND

3. Relays

- 3.1. NO
- 3.2. Common
- 3.3. NC

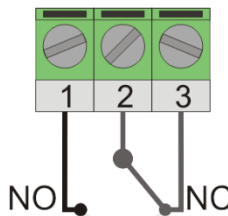
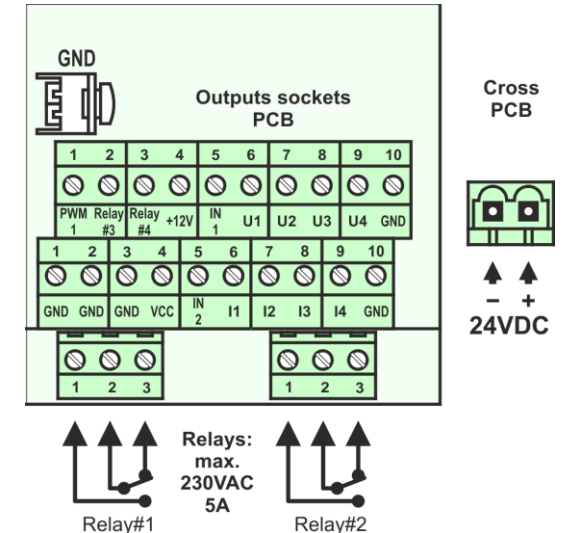
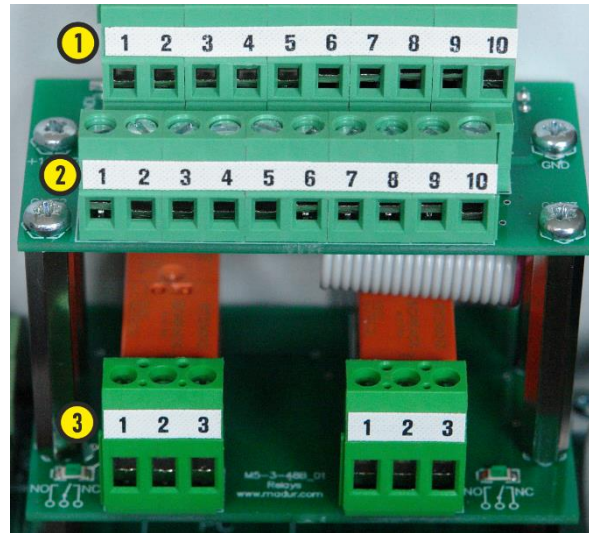

Relay 1 & 2

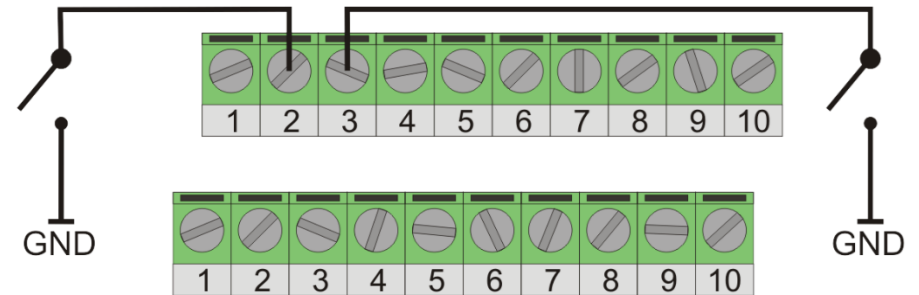

Relay 3

Relay 4